

A	3-way 4' x 3' corner	2	<p>Please review the parts you received on the pallet your frame is on to be sure you have all the parts.</p> <p>You will need about a 57'x15'6" area for your new batting cage. It is recommended you mark off this area before starting.</p>
B	3-way 4' x 3' corner	2	
C	4-way 4' x 3' corner	4	
D	10' lengths of pipe	14	
E	7' 10" lengths of pipe	4	
F	10' lengths of 2' pipe fluted at one end	6	
G	Ground Supports	8	
H	Net Hangers	26	
I	Self-drilling screws	42	
J	Drill Bit (for screws)	1	

Step 1 – Lay Out the Frame Components

Begin by laying out the batting cage frame on the ground.

1. Place two **3-way end corners** labeled **(A-B)** with the **3 foot sides facing each other** and approximately **15'6" apart**. These will form the first end arch.
2. Measure approximately **57 feet** from the first arch and place the remaining two **3-way end corners** labeled **(B-A)**, again with the **3 foot sides facing each other** and spacing them about **15'6" apart**.
3. Between the two end arches, place the four **4-way arch corners (C)**:
 - Position two on each side of the frame
 - Space them approximately **18 to 20 feet apart**
4. Organize the straight pipe sections that will be used during assembly:
 - **(D)** – 10' straight pipes
 - **(E)** – 7'10" straight pipes
 - **(F)** – Fluted 10' pipes

Step 2 – Assemble the Frame Arches

Assemble all four arches on the ground before standing them upright.

End Arches

Using the **3-way corners (A-B and B-A)**:

1. Attach one **10' pipe (D)** vertically to each **2 foot side** of the corner fittings to create the legs of the arch.
2. Connect the tops of the corners using one **7'10" pipe (E)**.

Center Arches

Using the **4-way corners (C)**:

1. Attach one **10' pipe (D)** vertically to each side of the corner fittings.
2. Connect the tops of the corners using one **7'10" pipe (E)**.
3. Insert one **self-drilling screw** into every connection point where pipes join the corner fittings.

At this stage, you should have:

- Two completed end arches
- Two completed center arches

Step 3 – Assemble the Top Side Runners

Complete this step while all arches are still on the ground.

End Side Runners

For each side and each end section:

1. Insert a **7'10" pipe (E)** into a **fluted 10' pipe (F)**.
2. Secure each junction with a **self-drilling screw** using the provided drill bit.

Center Side Runners

For the center section on each side:

1. Insert a **10' pipe (D)** into a **fluted 10' pipe (F)**.
2. Secure each junction with a **self-drilling screw**.

These assembled sections will become the top lengthwise runners connecting all arches together.

Step 4 – Stand and Connect the Frame

Extra help and a ladder are needed for this step.

1. Attach the assembled end side runners (**E-F**) into both sides of the first end arch corners (**A-B**) and (**B-A**).
2. Secure each connection with a self-drilling screw.

Standing the Frame

1. Carefully lift and hold the first end arch upright.
2. Have another installer raise the first center arch and connect the side runners to the **4-way corners (C)** on both sides.
3. Raise the second center arch and connect the assembled center side runners (**D-F**) to the **4-way corners (C)**.
4. Finally, raise the last end arch and connect the remaining side runners to complete the frame structure.
5. Insert self-drilling screws into every runner-to-corner connection.

Frame Complete

Your batting cage frame is now fully assembled.

Step 5 – Install Net Hangers and Netting

1. Attach the **Net Hangers (H)** to each arch:
 - One at each corner
 - One at the center of each arch width
 - Additional hangers spaced along the length runners
2. Position the hangers as needed to eliminate sagging in the batting cage net.
3. Beginning on one side, attach the batting cage net to the net hangers and continue around the frame until fully secured.

Diagram for assembling 2 pieces together and self tapping them

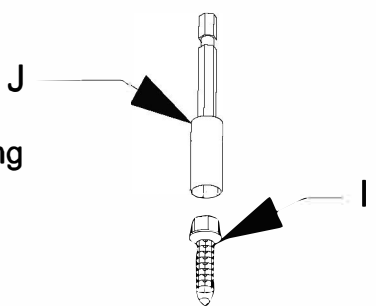
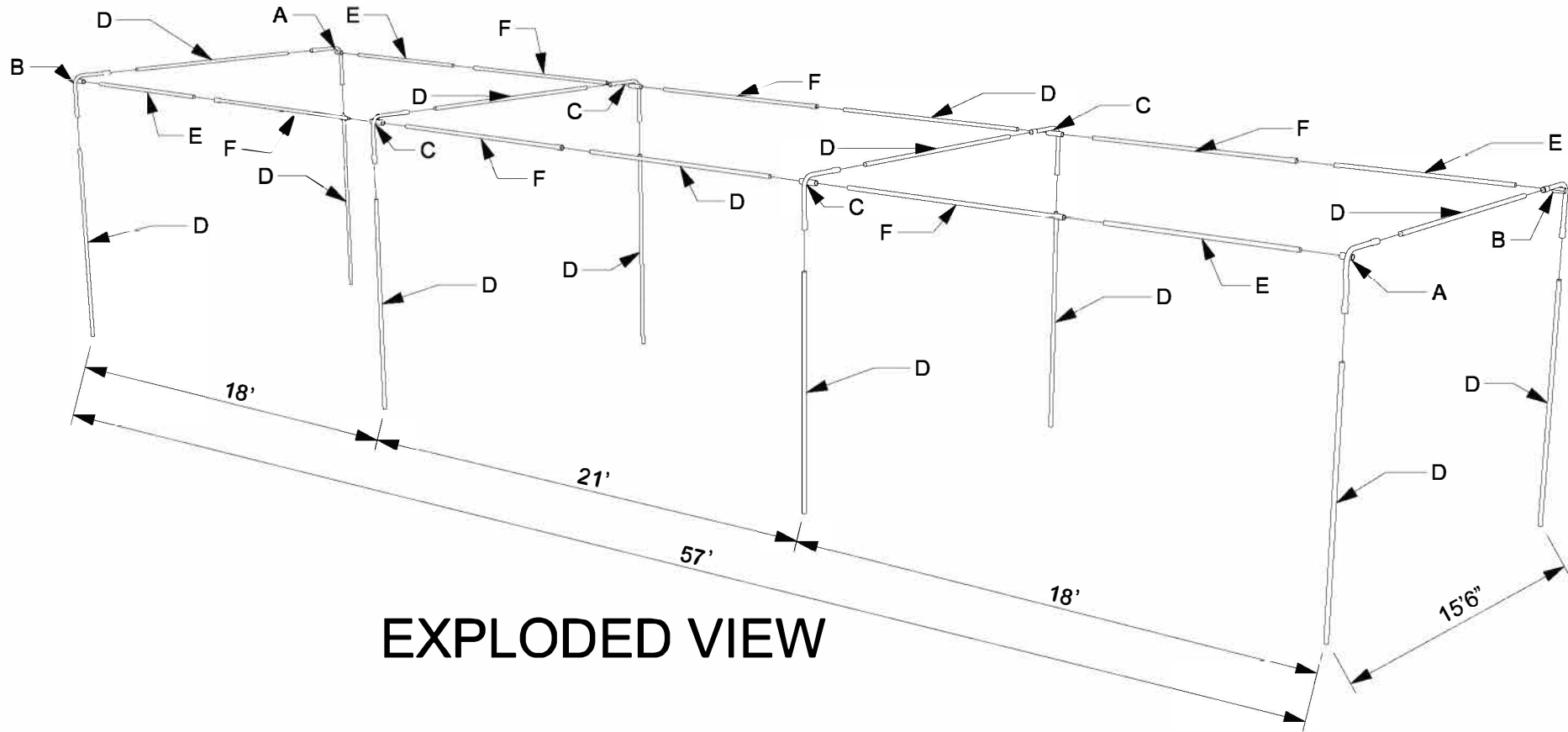
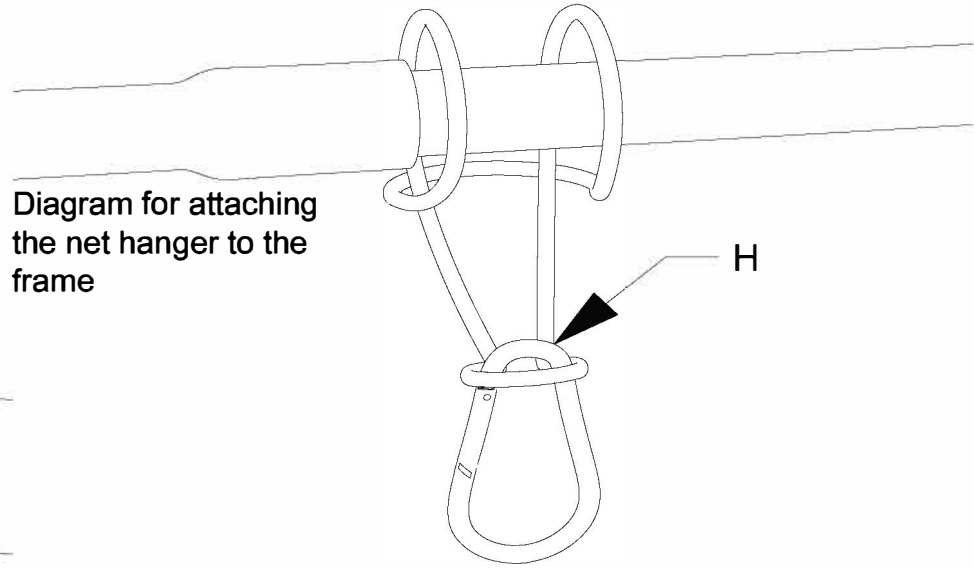

Diagram for attaching the net hanger to the frame



EXPLODED VIEW